

Countmaster bundle BS 446 with G10108



Standalone Counting machine with

Banding station included



Countmaster BS 446



Standalone Counting machine



Technical specification:

Max. counting speed:	depends to disk (page 5)
Paper quality:	depends to disk (page 5)
Max. paper cutsize:	350 - 600 mm
Min. paper cutsize:	55 x 100 mm
Max. packet height:	up to 200 mm
Min. packet height:	10 mm
Electrical connection:	Single phase / 230 V N/PE AC / 50-60 Hz. (+/- 10%)
Power total:	2.1 kW
Dimensions:	1640 x 788 x 1885 mm (L x B x H)
Weight:	approx. 195 kg

Countmaster BS 446

Layout:

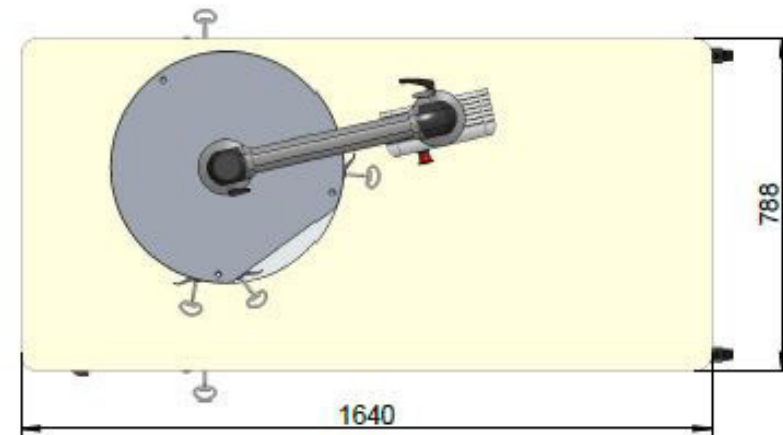
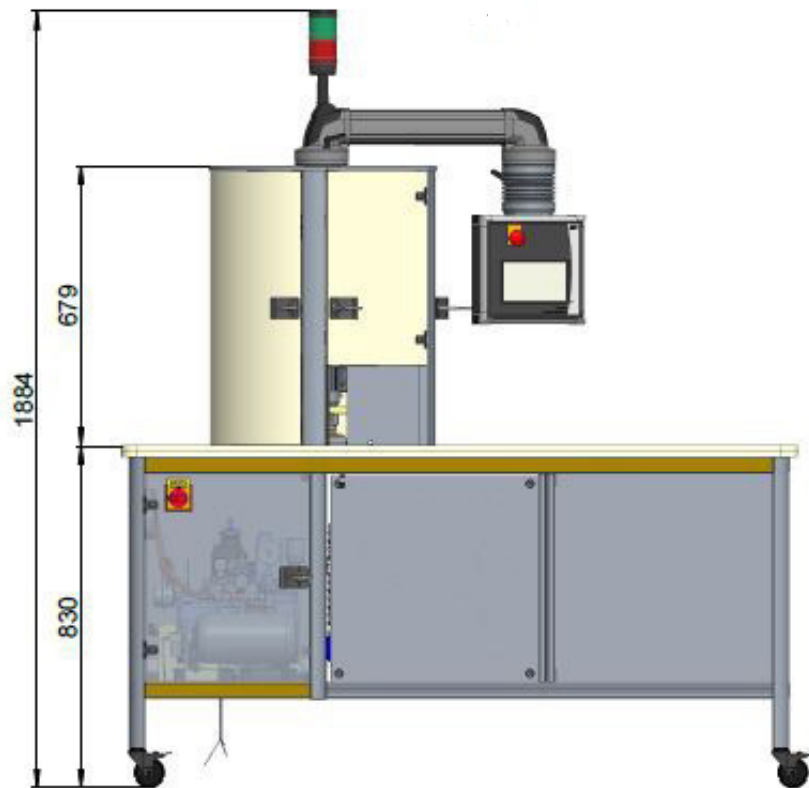

Basic configuration:

- Programmable Logic Controller available
- Operation and setup of the machine by multi-lingual full colour touch screen
- Easy and fast to operate
- Internal memory to store counting results
- Integrated vacuum pump
- Machine designed for multi-shift operation
- Maintenance unit for compressed air
- Save your counting results on an USB
- Counting results only deletable by authorized operators (password protection)
- Counting results (good/bad) can be symbolized by colours (green/red) in the full screen of the operating display
- Maintenance friendly
- Transport rolls

Countmaster BS 446

Counting disk information:

Features:	Zählscheibe V8	Zählscheibe V11	Zählscheibe V12	Counting disk V9
Number of segments	6	3	3	3
Diameter	119,6 mm	129,6 mm	129,6 mm	129,6 mm
Grammage	50 - 120 gramm	60 - 120 gramm	90 - 250 gramm	50 - 160 gramm
Paper offset	- 1 mm	- 2,5 mm	- 2,5 mm	- 2,5 mm
Max. counting speed	8600 notes / min.	4300 notes / min.	4300 notes / min.	4300 notes / min.
Max. counting speed with option tab inserter	-	2500 notes / min.	2500 notes / min.	2500 notes / min.
Range of application	corner counting	corner counting	corner counting	corner counting

Countmaster BS 446

Options:

- Special voltages (OP0036_10146_0)
- Integrated compressor (OP0004_10146_0)
- Table -prolongoation (OP0035_10146_0)
- Tab -insertion (OP0002_10147_0)
- USB, Ethernet, RS232 interface (OP0007_10146_0)
- Noise protection (OP0072_10146_0)

Bandpak 10108

Banding machine

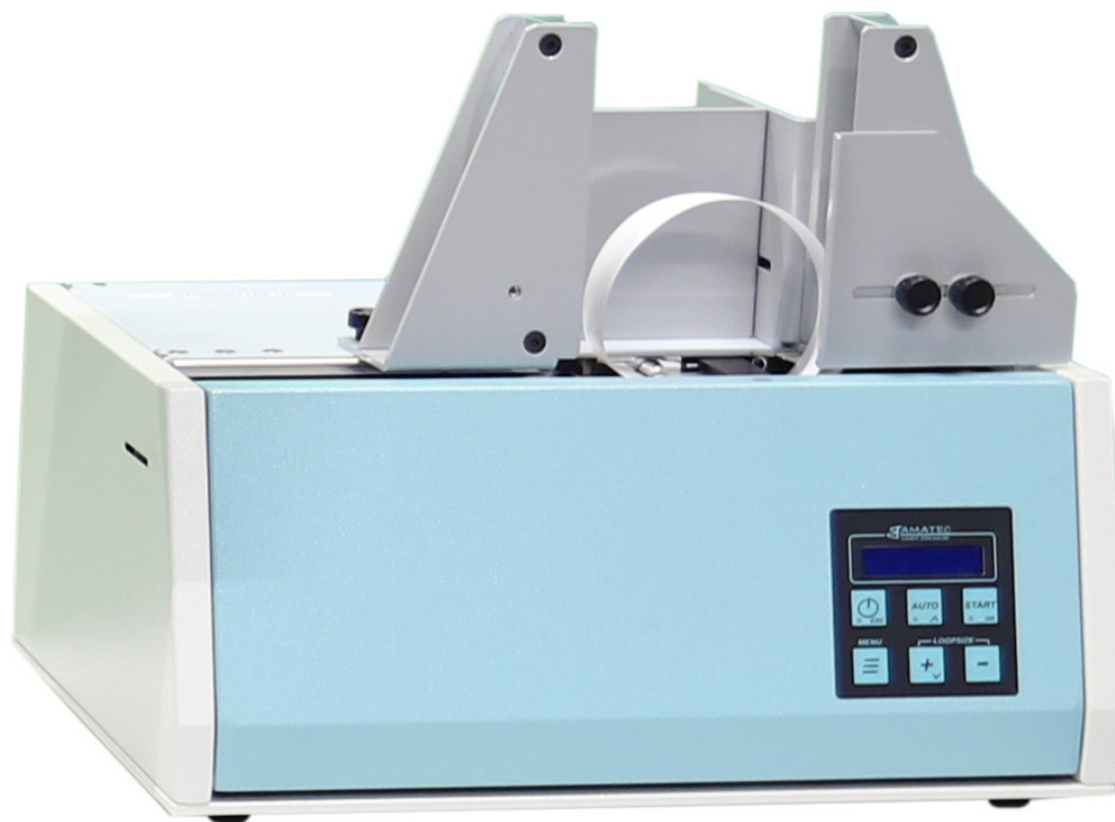

Bandpak 10108

Technical Data

Material:	Thermoband PE coated $\geq 80\text{g/m}^2$ and PP-Filmband
Band Width:	30 & 40 mm
Band Length:	150 m
Speed:	20-24 Bandings / min. depending on application / loop size
Sealing type:	Heat sealing
Dimensions:	L490xB360xH220mm
Electrical connection:	100-240V, 50/60Hz, 70W
Net weight:	36Kg
Product dim.:	Width 25-250 mm Height 5-210 mm

Basic configuration:

- Adjustable sealing temperature
- Variable loop size
- Adjustable track to suit different product sizes
- 3 Ways of operation, by hand- switch, foot- switch or automatic by start sensor